

**This electronic collection of documents is provided
for the convenience of the user
and is Not a Certified Document –**

**The documents contained herein were originally issued
and sealed by the individuals whose names and license
numbers appear on each page, on the dates appearing
with their signature on that page.**

**This file or an individual page
shall not be considered a certified document.**

6/23/16

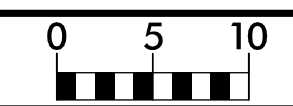

PROJ. REFERENCE NO.	SHEET NO.
BP14-R020	X-2

150 140 130 120 110 100 90 80 70 60 50 40 30 20 10 0 10 20 30 40 50 60 70 80 90 100 110 120 130 140 150

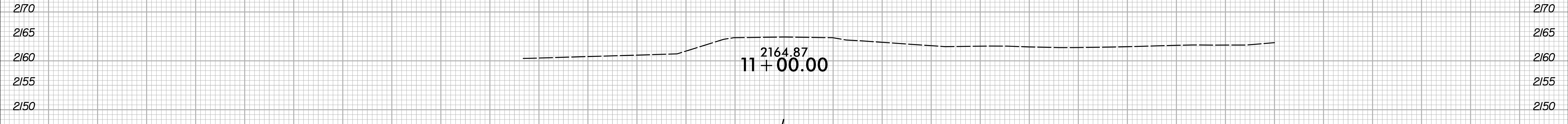
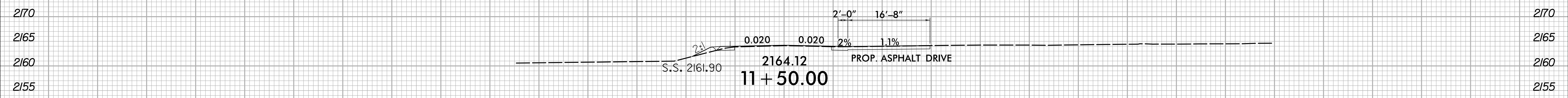
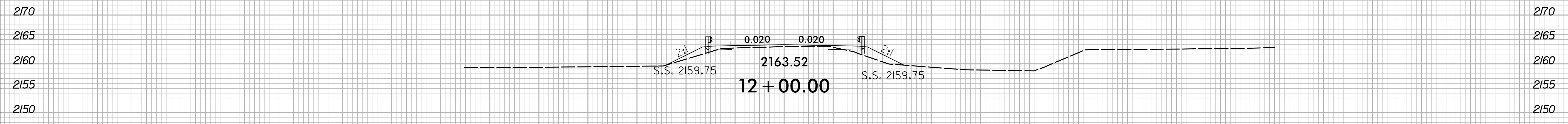
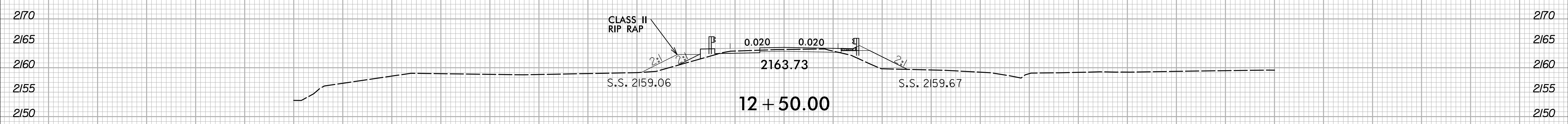
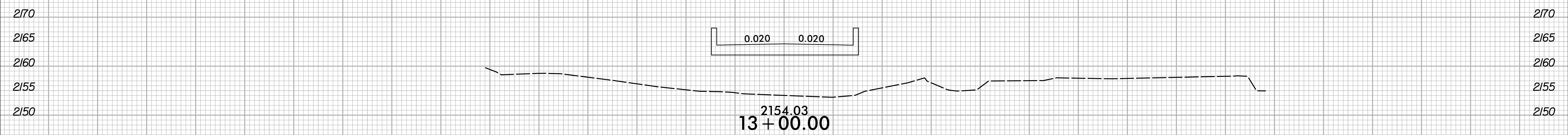
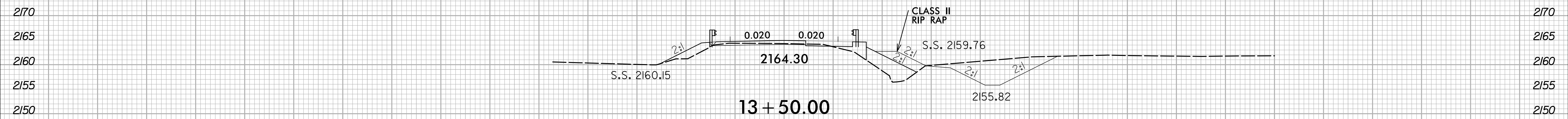

150 140 130 120 110 100 90 80 70 60 50 40 30 20 10 0 10 20 30 40 50 60 70 80 90 100 110 120 130 140 150

8/15/2024
 X:\NC000\Division 14 - 2017\Henderson 440015\Roadway\440015_Rdy_xpl.dgn
 User:sm14m

6/23/16

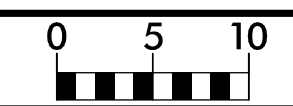

PROJ. REFERENCE NO.	SHEET NO.
BP14-R020	X-3

150 140 130 120 110 100 90 80 70 60 50 40 30 20 10 0 10 20 30 40 50 60 70 80 90 100 110 120 130 140 150

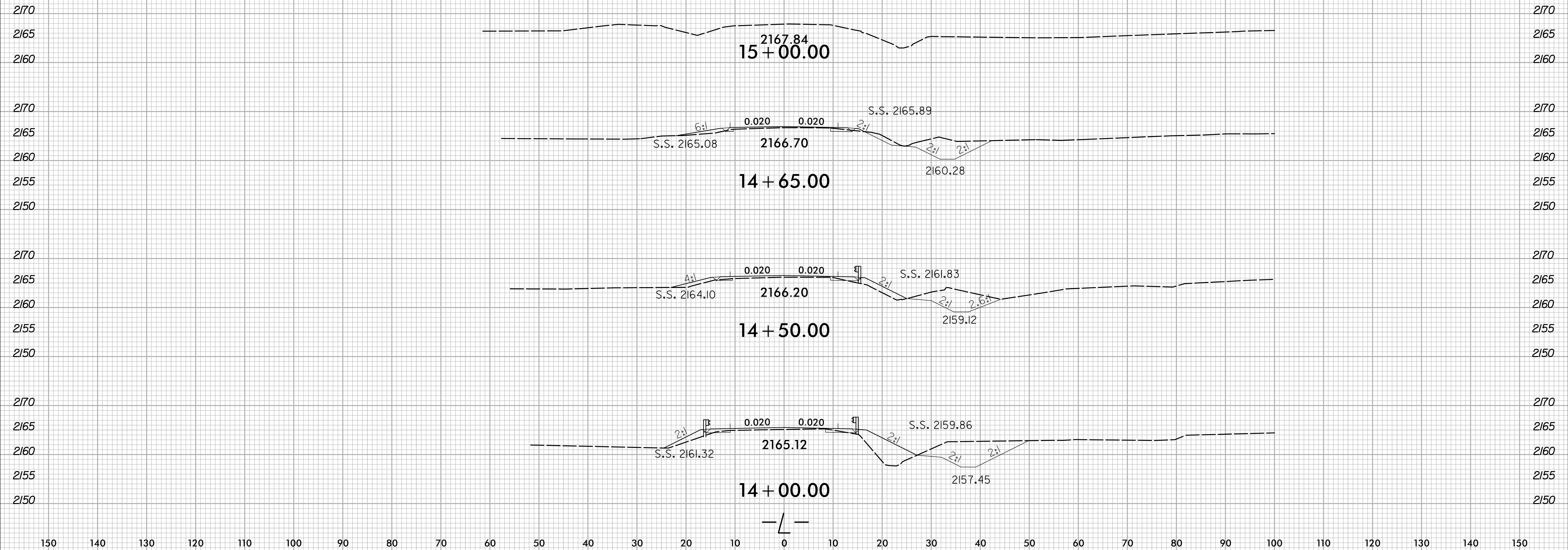

8/15/2024
 X:\NC000\Division 14 - 2017\Henderson 440015\Roadway\XSC\440015_Rdy_xpl.dgn
 User:rsme141m

150 140 130 120 110 100 90 80 70 60 50 40 30 20 10 0 10 20 30 40 50 60 70 80 90 100 110 120 130 140 150

PROJ. REFERENCE NO.

SHEET NO.

BP14-R020

X-1

STATE OF NORTH CAROLINA DIVISION OF HIGHWAYS

CROSS-SECTION SUMMARY

NOTE: EMBANKMENT COLUMN DOES NOT INCLUDE BACKFILL FOR UNDERCUT

Station	Uncl. Exc. (cu. yd.)	Embt (cu. yd.)												
11+00.00	0	0												
11+50.00	13	2												
12+00.00	15	17												
12+50.00	11	42												
12+63.70	5	15												
Station	Uncl. Exc. (cu. yd.)	Embt (cu. yd.)												
13+36.30	0	0												
13+50.00	3	26												
14+00.00	8	87												
14+50.00	4	56												
14+65.00	1	6												
15+00.00	2	4												

Approximate quantities only. Borrow excavation, fine grading, clearing and grubbing, and removal of existing pavement will be paid for at the lump sum price for "Grading".